

**INDUSTRY**

Packaging  
Fruit / Vegetable  
Food / Dairy / Cheese  
Pharmaceutical / Cosmetic  
Water / Wastewater  
Pulp & Paper  
Aerospace  
.... Unlimited...

**Available Features**

- Variable Speed Control
- Auto Reject
- Data Acquisition
- Historic and Live Data
- Remote Control
- Remote Visualization
- Email Notifications
- SMS Alarm / Texting
- Event Modeling
- Aggregate Raw Data
- Trend Calculations
- Linked Trend Bands
- High / Low Limits
- Time Shifting Trends
- CSV Exports

# Check Weighing

Series: CWS103A - Quality Inspection System for Weight

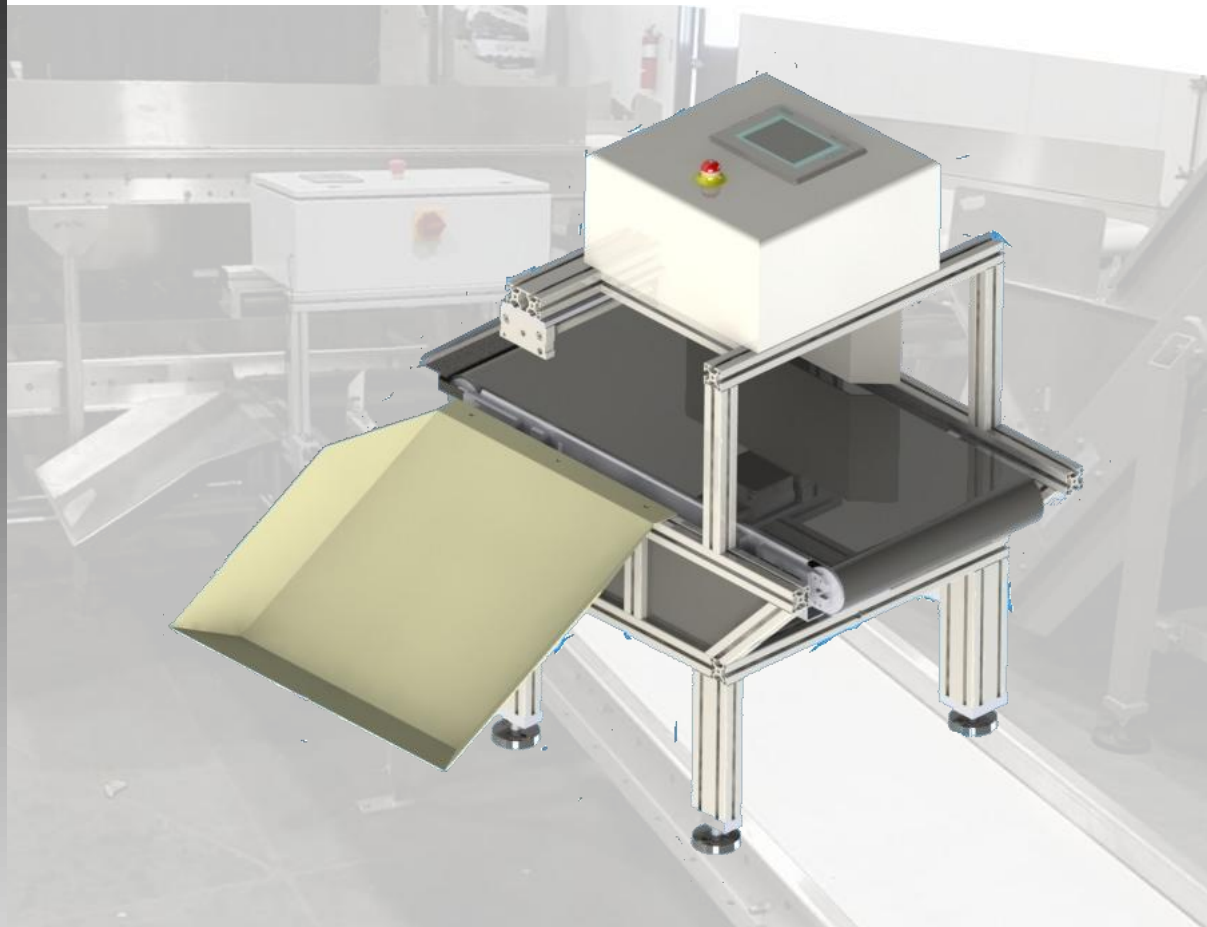

**This is our workhorse unit. With hundreds of these units installed across North America, and years of support and service, you can be sure your investment will stand the test of time. Built and Serviced right here.**

**Standard Systems Include but not limited to....**

- Stop Weight Control (with continuous option)
- Up to 30 Units per minute\*
- Up to 110 lbs (50 kg) packages
- Accuracy better than 1%\*
- Systems optimized for 2lb / 3lb / 5lb / 10lb products
- Up to 20 different selectable products
- In-process rejects
- Variable Speed Belt Control
- Upstream Enable Circuit
- Downstream Enable Permissive
- UL508A Control System

\*Depending on size, weight and speed, results may vary.



### Basic Unit

**BASE**

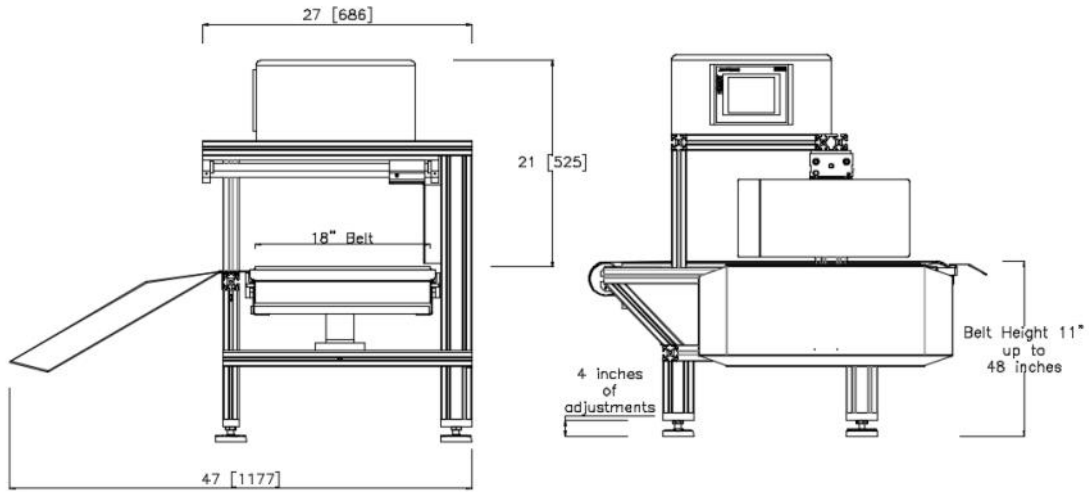

### OPTIONS

**OPTIONS**

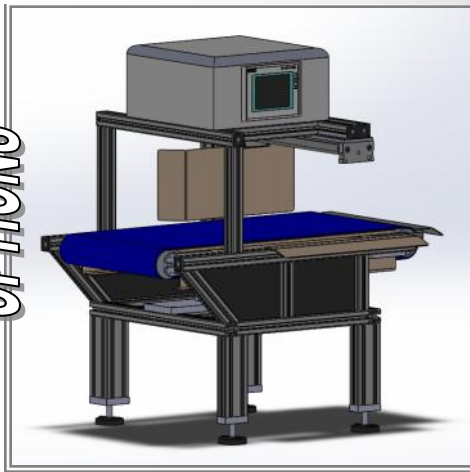

TEFLON PADDED TRANSITIONS

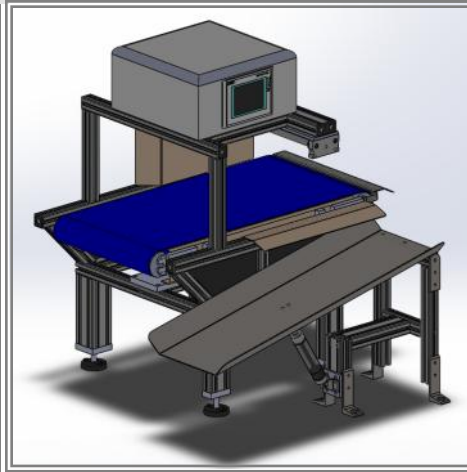

DROP PAN



EXTENDED LEGS



# SAFETY GUARDING

## Optional - Plant Floor Visualization / Reports / SMS Alarm Text and more....

- **Remote Visualization** - Watch your production, even acknowledge alarms remotely (password protected) from any location in the world.
- **Daily Reports** - Have daily / shift reports sent to your email.
- **Remote Control / Viewing** - Once your system has been made live to our cloud based data center via a 256 bit encrypted VPN / Firewall, you will be able to:
  - View Machine Screens like you are right in front of the machine.
  - Monitor all production remotely;
  - View / Control process (Password Protected)
- **Expandable** - All of our systems are fully expandable. Let us grow with you.

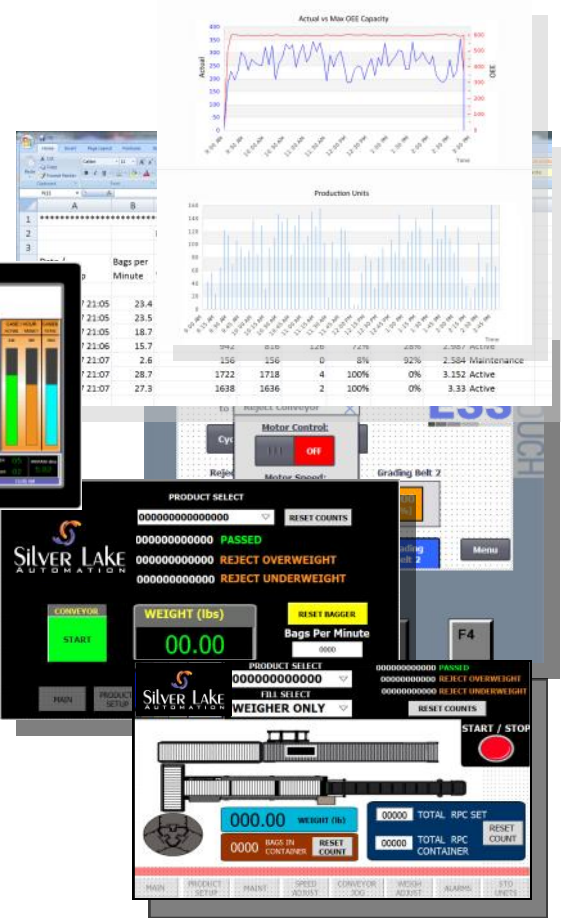

	CSV / Excel Compatible	DELIVERED DATA	CUSTOMIZE DASHBOARD	REPORT GENERATION	HISTORICAL TRENDING	REMOTE ACCESS	ONLINE	EXPANDABLE
BASE	•							
INTERMEDIATE	•	•						
ENTERPRISE	•	•	•	•	•	•	•	•

\* Though a feature may be listed, not all features are included. Please ensure that all the features you desire are included with your order. It is recommended that you review your order with a Silver Lake Systems Engineer during the ordering process.

### ORDERING INFORMATION

Check Weigher CWS 103

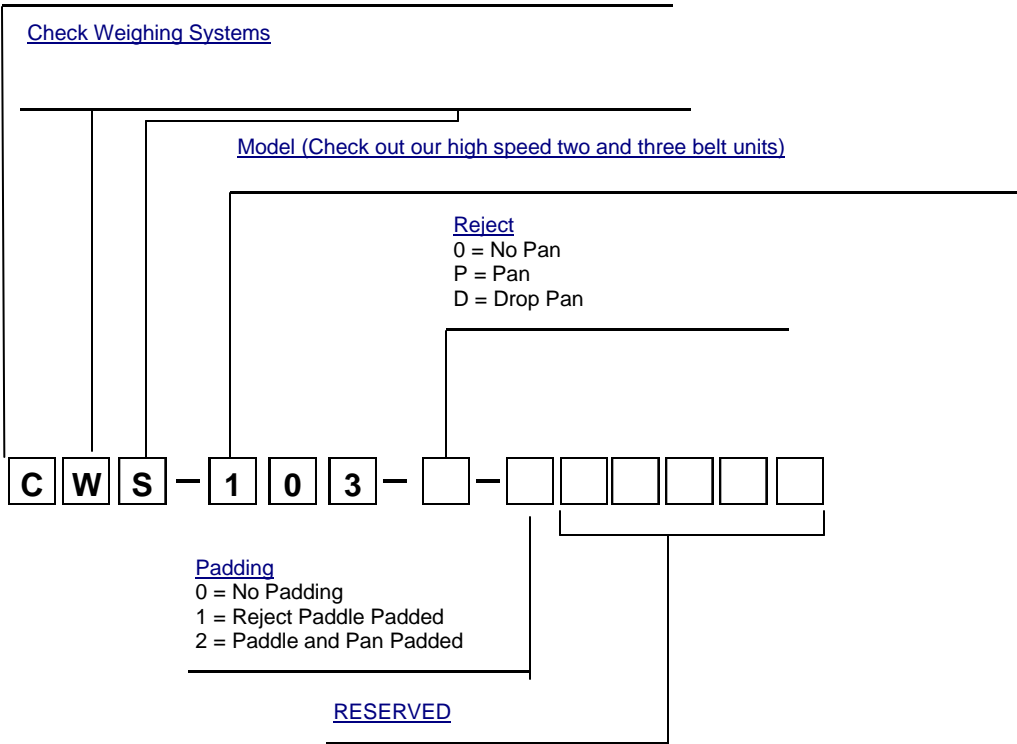

**Enter Additional Notes Here. (If more room is required attach sheet)**

**CLOSE, BUT NOT EXACTLY** what you are looking for? Don't worry. Each system is built to order. We like to call it "*Customization at no extra cost*". You are not paying a surcharge for customizing of a standard product. All you pay for is what you add. Our production system has been specially designed to handle custom systems. Tell your sales representative what you want. We'll have a quote out to you right away.

**APPROVAL DRAWINGS**  
 Approval drawings are available for each system. We encourage it. You get to review the system before we build it. Request them with the order.

YOUR LOCAL REPRESENTATIVE